

3 Valve Flat type

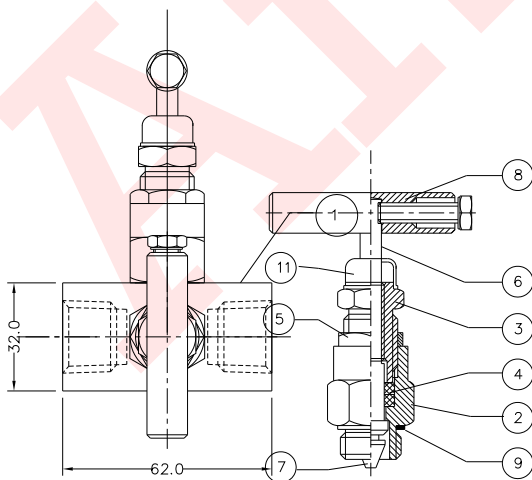

AmLock

AMI MARKETING SERVICES

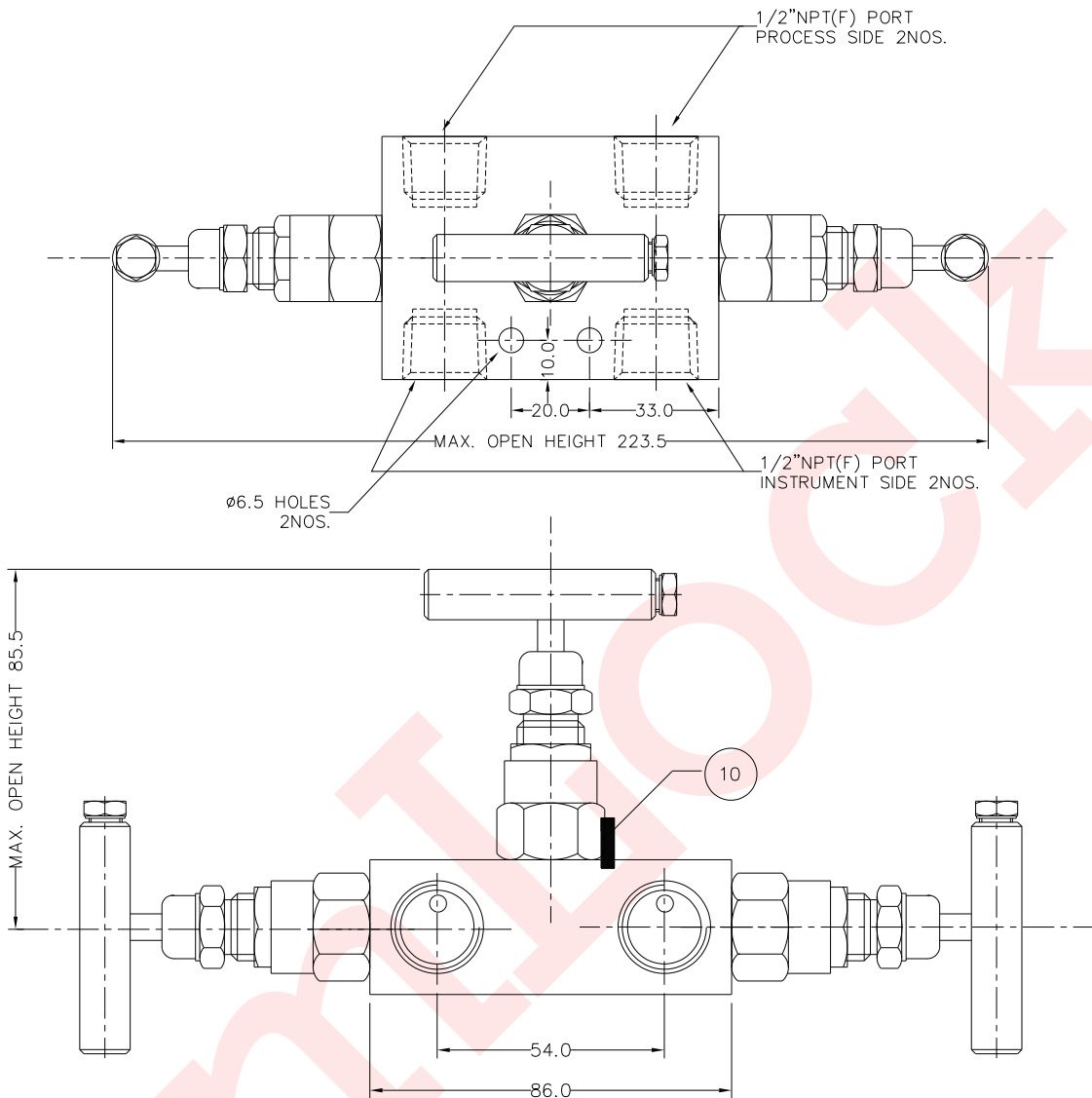

PART No.	PART DESCRIPTION	MATERIAL	QTY
1	BODY	SS 316	1
2	GLAND BODY	SS 316	3
3	GLAND RETAINER	SS 316	3
4	GLAND SEAL	P.T.F.E.	6
5	CHECK NUT	SS 316	3
6	SPINDLE	SS 316	3
7	TRIM	SS 316	3
8	HANDLE	SS 304	3
9	WASHER	S.S.	3
10	LOCK PIN	S.S.	3
11	DUST CAP	P.V.C.	3

CLIENT : P.O. No. : P.O. Sr.No. : QUANTITY : TEST PRESSURE : Refer This Number As drawing No.	DO NOT SCALE DRAWING TOLERANCES UNLESS SPECIFIED INCH (0.00") ± 0.025" METRIC (0.0mm) ± 0.40mm (0.000") ± 0.007" (0.00mm) ± 0.20mm	All Dimensions are in millimeters unless specified FLOW DIGRAM 	REV: 00 DATE: DRN BY: CHECKED: APPROVED:	TITLE 3VALVE MANIFOLD FLAT TYPE PART NO: AM-3VM/F NO. AM-3VM/F
	FILED LOCATION C:\SUHAS\PARTNOWISE\No. This Drawing Is In Third Angle Projection		AmLock AMI MARKETING SERVICES	