

3 Valve T Type

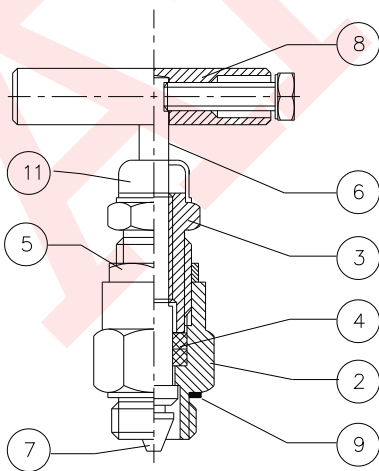

AmLock

AMI MARKETING SERVICES

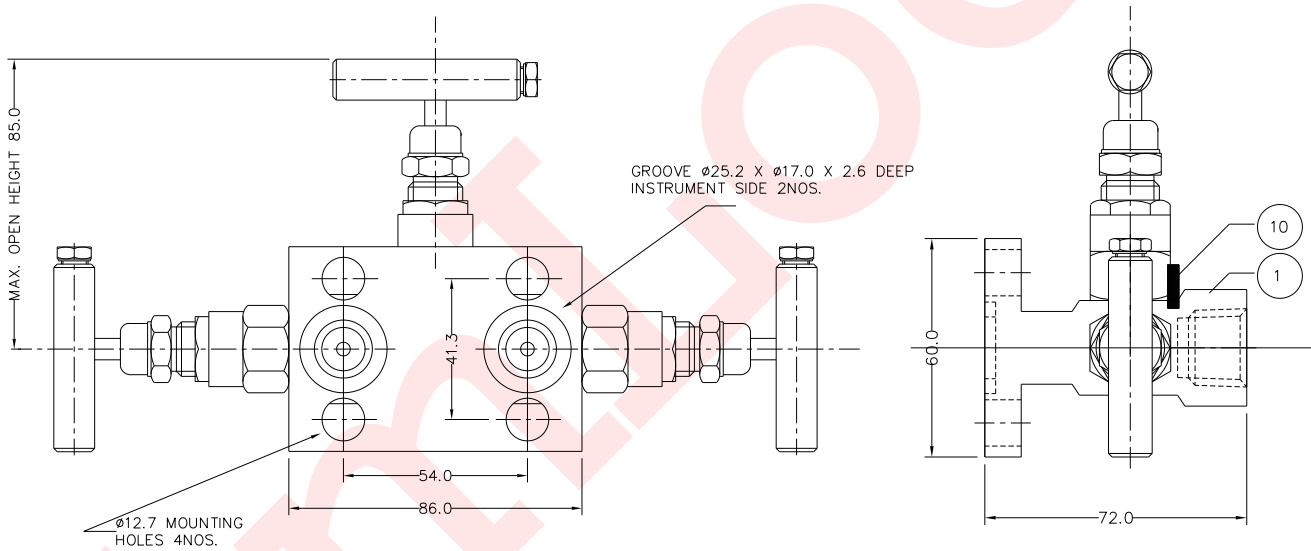
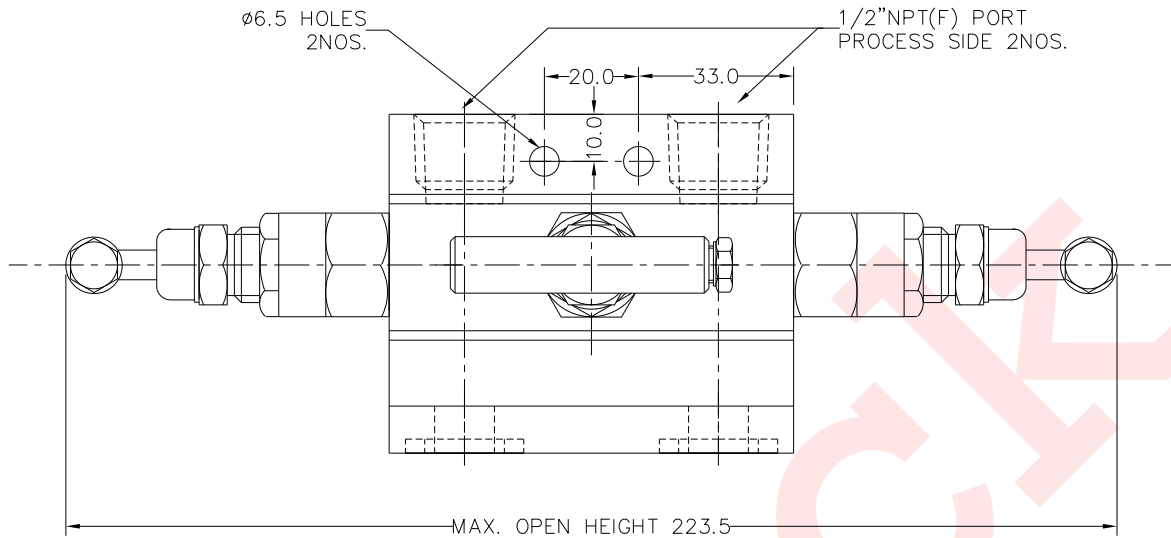

PART No.	PART DESCRIPTION	MATERIAL	QTY
1	BODY	SS 316	1
2	GLAND BODY	SS 316	3
3	GLAND RETAINER	SS 316	3
4	GLAND SEAL	P.T.F.E.	6
5	CHECK NUT	SS 316	3
6	SPINDLE	SS 316	3
7	TRIM	SS 316	3
8	HANDLE	SS 304	3
9	WASHER	S.S.	3
10	LOCK PIN	S.S.	3
11	DUST CAP	P.V.C.	3

CLIENT : P.O. No. : P.O. Sr.No. : QUANTITY : TEST PRESSURE : Refer This Number As drawing No.	DO NOT SCALE DRAWING	All Dimensions are in millimeters unless specified FLOW DIGRAM 	REV: 00	TITLE	3VALVE MANIFOLD T'TYPE PART NO : AM-3VM/T	
	TOLERANCES UNLESS SPECIFIED INCH METRIC (0.00") \pm 0.025" (0.0mm) \pm 0.40mm (0.000") \pm 0.007" (0.00mm) \pm 0.20mm		FILED LOCATION C:\SUHAS\PARTNOWISE\No.	DATE:	NO.	AM-3VM/T
	This Drawing Is In Third Angle Projection		DRN BY:	AmLock AMI MARKETING SERVICES		
			CHECKED:			
			APPROVED:			